

SUPPLEMENTARY INFORMATION

A Macroscopic Device Described by a Boltzmann-Like Distribution

Simon Tricard,[†] Claudiu A. Stan,^{†,*} Eugene I. Shakhnovich and George M. Whitesides*

Department of Chemistry and Chemical Biology, Harvard University, 12 Oxford Street,

Cambridge, MA 02138

Abstract. This supplementary information document contains: (1) additional information about the experimental setup; (2) all distinct folding shapes for each conformation of the chain; (3) values of the $E_{j,MA}/T_{MA}$ parameters for distinct experiments; and (4) a comparison between experimental measurements and the predictions of the Boltzmann model based on thermodynamic degeneracy values.

* corresponding authors: claudiu.stan@alum.mit.edu, gwhitesides@gmwgroup.harvard.edu

[†] these two authors have contributed equally to this work

1. Further Information about the Experimental Setup

The flat surface on which the objects were agitated (1.2×1.2 m square, ~7 kg weight) was made from an aluminum honeycomb panel and was supported from the ceiling via an elastic cord joined to four cables which were anchored to the corners of the panel. The distance between the plate and the attachment point to the ceiling was 1.3 m. We attached to the center of the plate, below it, a pendulum made from a light (~0.1 kg) 0.3-m rigid rod with an end weight with a mass of 1.4 kg. The pyramid defined by the panel and the cables was wrapped in a polyvinyl chloride (PVC) film to control the humidity above the plate. We maintained a relative humidity higher than 60% using an air humidifier (Vicks V5100NS). To record pictures of the system during agitation, we used a photo camera (Nikon D40) that was suspended ~1 m vertically above the plate.

To achieve pseudo-random agitation, we applied two shaking drives: one from an orbital shaker attached to the plate, and one from a linear actuator which kicked the weight of the pendulum under the plate. The orbital shaker (Madell Technology Corp., ZD-9556-A) was attached to the plate via an elastic polyurethane cord, and the motion it imparted to the plate was a combination of orbital translation with a small-amplitude angular oscillation. The radial amplitude of the orbital shaker was 5.1 mm, and its frequency was variable; we used orbital frequencies ranging from $f = 80$ to $f = 160$ revolutions per minute (rpm). The second shaking motion had the role of randomizing the orbital motion. We kicked with a linear actuator (LinMot, Inc., P01-23x80) the weight under the plate; the linear actuator moved at a fixed frequency of 4 Hz in all experiments, but the times at which it impacted the pendulum were not periodic due to the complicated motion of the pendulum. The frequency of kicks was higher than the frequency of orbital shaking, and the system did not complete a full orbit between kicks to the pendulum. The overall motion of the plate was aperiodic but not entirely random, and we estimated that the maximum horizontal acceleration of the plate was approximately 5 m/s^2 .

The flexible links in the chain were weakly elastic and were made from a nylon string on which we strung three 3.18-mm diameter PMMA spheres. Aluminum crimps fixed the beads on the string and controlled the elasticity of the chain, as described previously.¹ To improve the accuracy of the automatic analysis, we dyed the two end cylinders of the chain blue.

2. The Calculation of Degeneracy Factors by the Thermodynamic Method

Fig. S1 shows the details of the calculation of degeneracy factors by the thermodynamic method. For the C2 and C3 conformations, there are multiple distinct folded shapes that cannot be transformed into another one by an operation of symmetry, and for the extended conformation C1 there is only one such shape; the figure shows all these shapes. The thermodynamic degeneracy numbers are equal to the number of distinct folding shapes within each conformation.

Figure S1 Calculation of the thermodynamic degeneracy factors g_i .

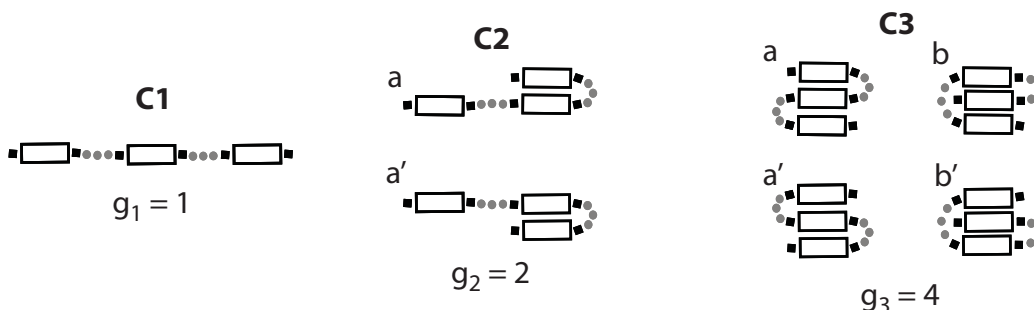

3. The $E_{j,MA}/T_{MA}$ Values Obtained from Individual Experiments

Figure S2 shows the individual values of $E_{j,MA}/T_{MA}$ obtained from the experimental measurements of conformation probabilities, using degeneracy values calculated by the empirical method. For clarity, we omitted the data points collected at $f = 100$ rpm, because application of Eq. (8) in the main paper to experiments in which we measured $P_3 = 0$ resulted in infinite values of $E_{3,MA}/T_{MA}$. The values of $E_{j,MA}/T_{MA}$ decreased as FR and f increased.

Figure S2. The values of E_2/T_{MA} and E_3/T_{MA} , calculated using degeneracy values determined by the empirical method. The data sets for different agitation frequencies have been shifted horizontally for clarity. The error bars represent the uncertainty of measurements.

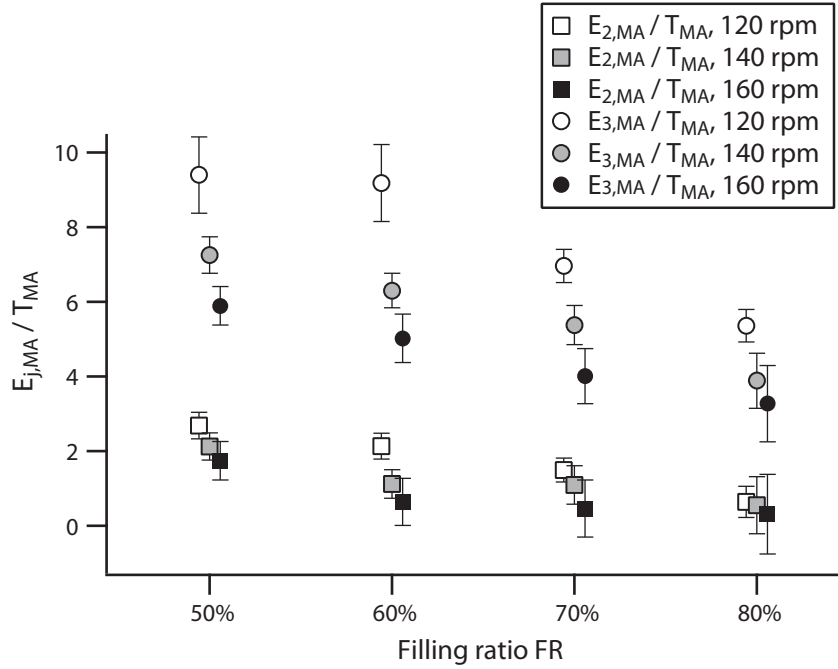

4. The Fit Quality of the Boltzmann-Like Distribution with Thermodynamic Degeneracy Factors

Fig. S3 shows the comparison between measurements and the Boltzmann-like distribution determined using thermodynamic degeneracy factors. The agreement between the distribution and experimental data was significantly worse than in the case (shown in Fig. 4 in the main paper) of empirical degeneracy values. For thermodynamic degeneracy values, the dependencies of T_{MA} on f and of $E_{j,MA}$ on FR were not monotonic, and we could not fit these dependencies with simple analytical functions. The predictions shown in Fig. S3 were calculated only for the discrete values of T_{MA} and $E_{j,MA}$ that we obtained using the mathematical procedure described in eqn (6), (7) and (8) in the main paper; the prediction line in graphs connects the probability values calculated for the discrete values of f and FR that we investigated in

experiments. Only 9 of 48 predicted probabilities fell within one experimental standard deviation of measurements, and 18 of 48 within two standard deviations, compared to 38 of 48 and 47 of 48, respectively, in the case of empirical degeneracies.

Figure S4. Comparison between experimental measurements and the Boltzmann-like statistics, for the case of thermodynamic degeneracy values. The solid circles, connected by thin dashed lines, indicate experimental measurements, and the open squares, connected by solid lines, show the predictions of the Boltzmann-like statistics.

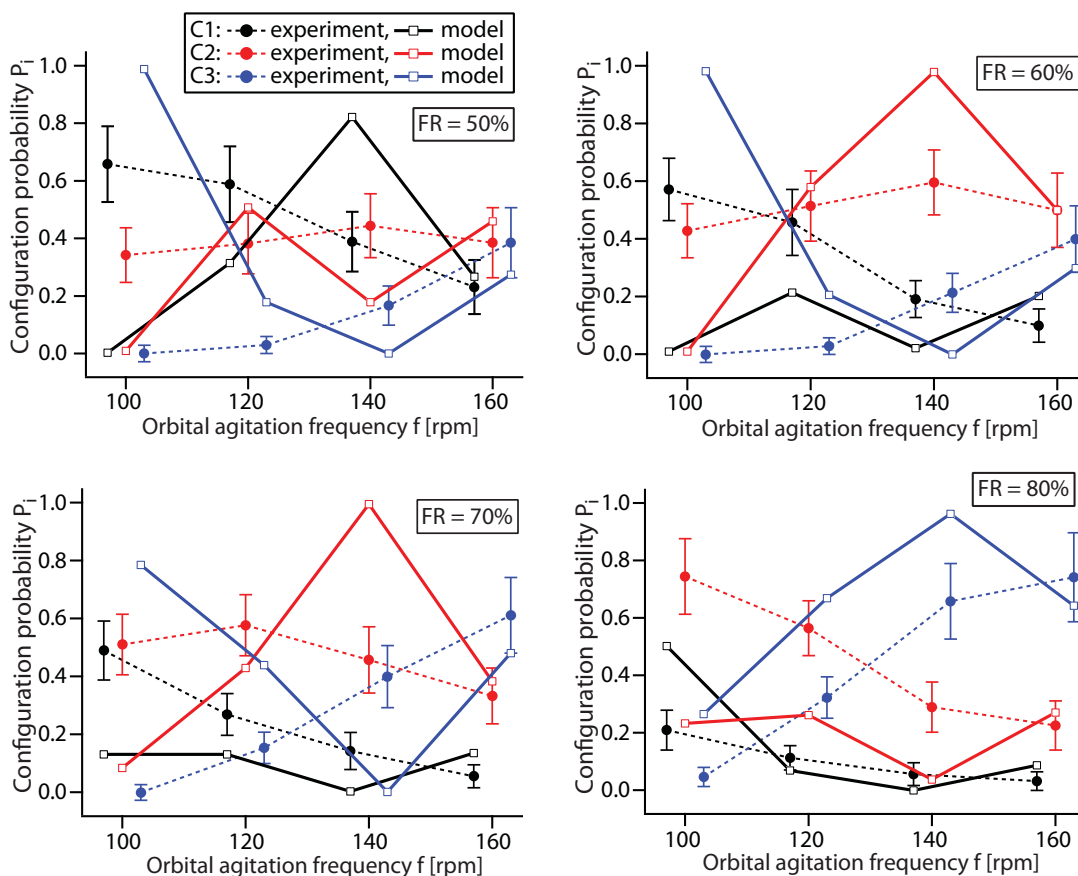

References

1. M. Reches, P. W. Snyder and G. M. Whitesides, *P. Natl. Acad. Sci. USA*, 2009, **106**, 17644-17649.